



# Vertical Summit™

Presented by

Dana Wiggin

Vice President, Distribution Sales

don't settle  
for less! >



800.873.5528

WWW.TARGETD.COM

# New Product Review

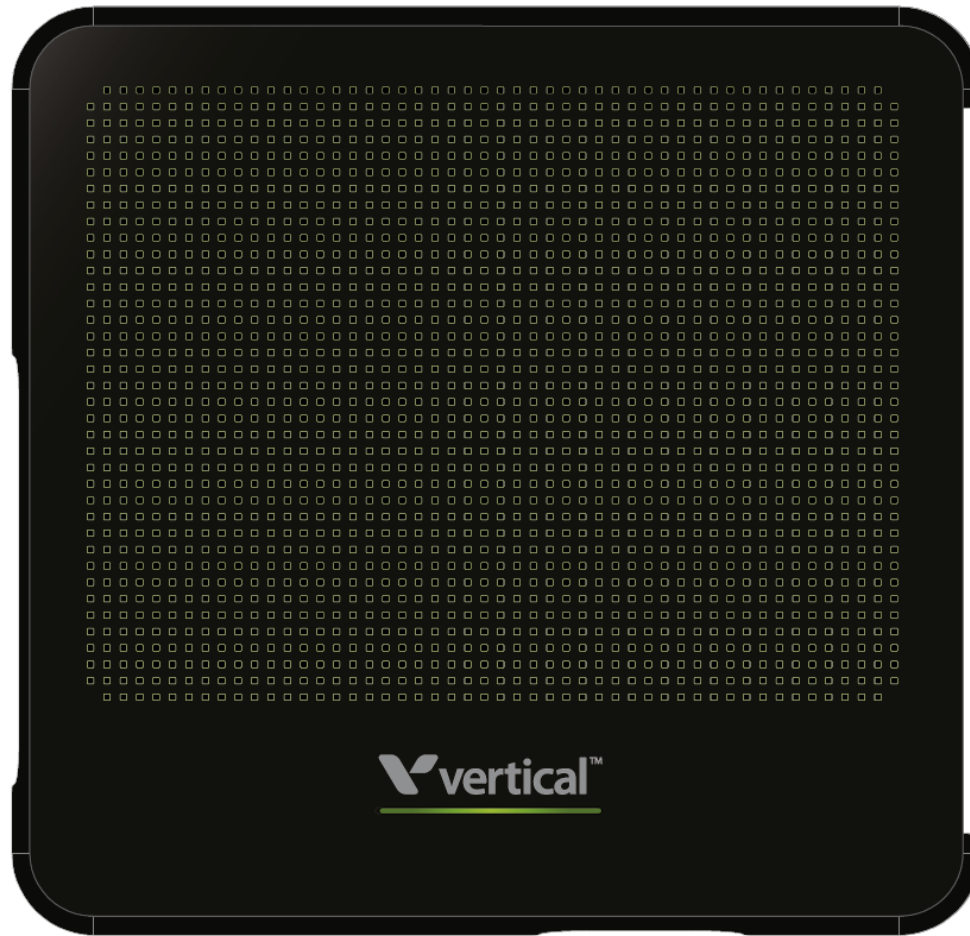

# Introducing the Vertical Summit

- Partnership with Ericsson-LG
- Ideally suited for 5-50 users – yet grows to 100+!!
- Competitively priced feature leader
- Provide SMB customers with the features and applications to support:
  - Mobility
  - UC
  - BYOD... for the right price!!

# Comprehensive Portfolio

## Wave IP 20-500 Mkt

- High Value Solution
- UC & Enterprise Mobility
- 20-500 users / Multi-site

## MBX IP 20-200 Mkt

- Advanced UC Apps / Hospitality
- Large Hybrid IP Key System
- 50-324 Users

## Vertical Summit 5-50 Mkt

- Advanced UC Apps / Mobility
- Medium Hybrid IP Key System
- 5-50 Users

## SBX IP 0-20 Mkt

- Price Leader
- Small Hybrid IP Key System
- <25 Users



## Product Overview

don't settle  
for less! >

# Architecture

A converged hybrid architecture that supports advanced UC/Mobility applications

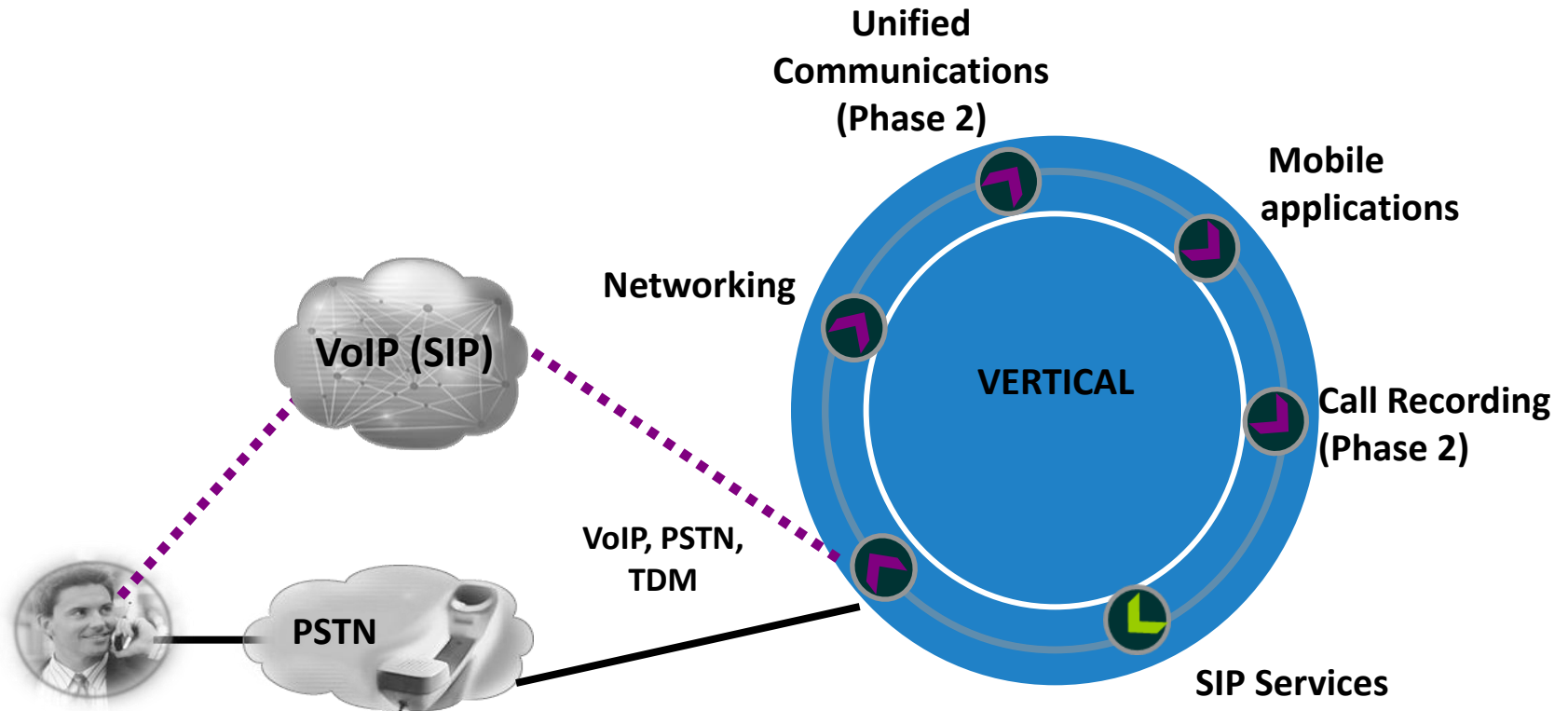

# Vertical Summit – Rich Features

- Integrated Auto Attendant/Voice Mail
  - Station
  - Group
  - CCR Routing
  - Name Directory
- Voice Mail to Email Notification and .wav Message
- Automatic Call Distribution
- Call Routing
- IP Fax Support
- Conference
  - Station and System
  - 13 Members
  - 20 Groups
  - Password protected
- Hot Desking
- Mobile Extension\*
  - Station and Hunt Group
- SIP Extensions\*
- SMDR
- Traffic Analysis
- Green Power Save

\*license needed

# Value Proposition

## Easily Expandable

- Base System + Expansion
- Trunks: Max 74
- Stations: Max 108 SLT/Digital
- IP/DECT capabilities to 140!

## Expanded VoIP & Mobility

- VoIP: Max 16 (8 on board)
- On/Off premise mobility

## Rich Features & Applications

- Enhanced VM/AA
- Unified Communications
- Robust application offerings

## Simple to Install & Manage

- Web Administration
- Install Wizard
- Broad endpoint support



# The Basics

## Hybrid IP PBX for SMB

Native VoIP technologies

## Seamless Expandability

2 KSU + 2 expansion slots per KSU



## Sweet Spot

5-50 users

## Advance Applications

Robust features and advanced applications

| Chassis   | Market Segment | TDM Maximum | PRI/DECT/IP Maximums |
|-----------|----------------|-------------|----------------------|
| Basic     | 5-30 Users     | 12/24       | 62/108               |
| Expansion | 30-50 Users    | 24/64       | 74/140               |

# Port Configuration

## VS-5000-00

- Trunks
  - Max ports 28
  - Base + Exp Max ports 40
- Extensions
  - Max ports 108
  - Base + Exp Max ports 140
    - Includes DECT

|                     |                         | KSU         | EKSU | MAX |
|---------------------|-------------------------|-------------|------|-----|
| <b>Trunks</b>       | Max Ports               | 28          | 12   | 40  |
|                     | Analog Trunk            | 12          | 12   | 24  |
|                     | PRI/T1                  |             |      |     |
|                     | IP Trunk (SIP H.323)    | 16          |      | 16  |
| <b>Extensions</b>   | Max Ports               | 108 (note*) | 32   | 140 |
|                     | SLT                     | 28          | 32   | 60  |
|                     | Digital                 | 24          | 24   | 48  |
|                     | Hybrid (SLT or Digital) | 16          | 24   | 40  |
|                     | IP                      | *32         |      | *32 |
|                     | DECT                    | 48          |      | 48  |
| <b>VM</b>           | without VVMU            | 4           |      | 4   |
|                     | with VVMU               | 8           |      | 8   |
| <b>VoIP Channel</b> | without VVMU            | 8           |      | 8   |
|                     | with VVMU               | 16          |      | 16  |

\*Note: DSIB(12) + DECT(48) + SLIB(16) + IP PHONE(32) = 108

# Port Configuration

## VS-5001-PRI

- Trunks
  - Max ports 48
  - Base +Exp Max ports 60
- Extensions
  - Max ports 108
  - Base +Exp Max ports 140
    - Includes DECT

|                     |                         | KSU | EKSU | MAX |
|---------------------|-------------------------|-----|------|-----|
| <b>Trunks</b>       | Max Ports               | 48  | 12   | 60  |
|                     | Analog Trunk            | 8   | 12   | 24  |
|                     | PRI/T1                  | 24  |      | 30  |
|                     | IP Trunk (SIP H.323)    | 16  |      | 16  |
| <b>Extensions</b>   | Max Ports               | 108 | 32   | 140 |
|                     | SLT                     | 28  | 32   | 60  |
|                     | Digital                 | 24  | 24   | 48  |
|                     | Hybrid (SLT or Digital) | 16  | 24   | 40  |
|                     | IP                      | *32 |      | *32 |
|                     | DECT                    | 48  |      | 48  |
| <b>VM</b>           | without VVMU            | 4   |      | 4   |
|                     | with VVMU               | 8   |      | 8   |
| <b>VoIP Channel</b> | without VVMU            | 8   |      | 8   |
|                     | with VVMU               | 16  |      | 16  |

# Summit

- USB Host Port
- Paging Port
  - (35) Zones Internal
- Relay
- Alarm/Doorbell
- Serial Port/RS232C
- Music Sources
  - 1 Internal with (13) Melodies
  - 1 External Source Input
  - (5) SLT Ports



# Summit 9000 Series Phones

- Intuitive User Interface
- High resolution and backlit LCD display
- HD Voice for all models
- Full-duplex speakerphone



# Summit 30-Button Phone

- VU-9030-00
  - 3 Line LCD with backlit
  - 3 Soft keys
  - 30 Programmable buttons
  - 7 Fixed buttons
  - Wall Mountable



# Summit 8-Button Phone

- VU-9008-00
  - 2 Line LCD with backlit
  - 8 Programmable buttons
  - 7 Fixed buttons
  - Wall mountable



# Summit DSS

- VU-9048-00
  - 48 Programmable buttons
  - Compatible with VS-9030-00
  - Up to five DSS consoles supported





# Endpoint Support

Broad range of endpoint support

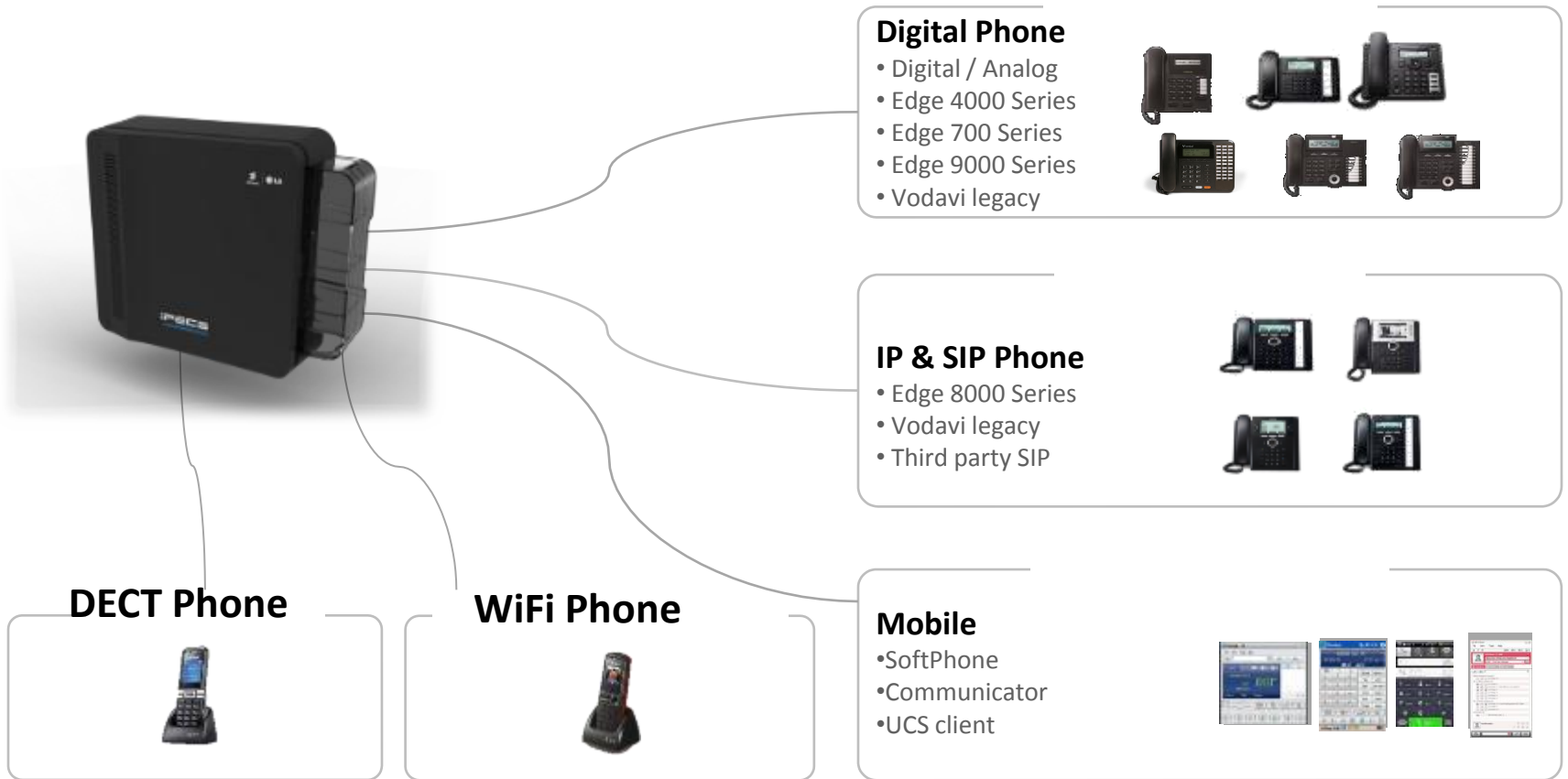

# Value Proposition

## Easily Expandable

- Base + Exp
- Trunks: Max 74
- Stations: Max 108 SLT/Digital
- IP/DECT capabilities to 140!

## Expanded VoIP & Mobility

- VoIP: Max 16 (8 on board)
- On/Off premise mobility

## Rich Features & Applications

- Enhanced VM/AA
- Unified Communications
- Robust application offerings

## Simple to Install & Manage

- Web Administration
- Install Wizard
- Broad endpoint support

# VoIP and Mobility Features

## Cost Effective & Expandable VoIP & Mobility

*“Start with built-in VOIP card for smaller needs and expand with the option VoIP for future use”*

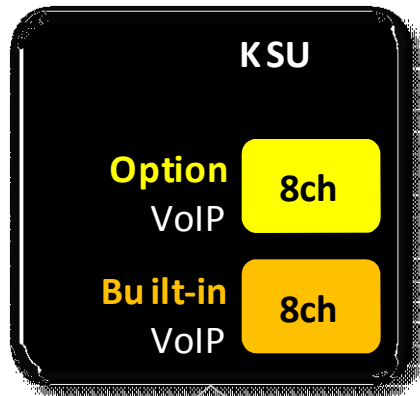

Max 16ch

DECT Phone



Communicator



*“Cost effective mobility and multi-site connections”*



VoIP providers

SIP Trunking  
SBX/MBX Networking

Remote Office



On the road



# VoIP Expandability

| BKSU          |         |                   |           | VVMU Expansion Board |         |                   |           |
|---------------|---------|-------------------|-----------|----------------------|---------|-------------------|-----------|
|               | Default | Option            | Sub-Total |                      | Default | Option            | Sub-Total |
| VoIP Channels | 2       | 1 port license x6 | 8         | VoIP Channels        | 0       | 1 port license x8 | 8         |

| Total VoIP Channels |      |       |
|---------------------|------|-------|
| KSU                 | VVMU | Total |
| 8                   | 8    | 16    |

# Voice Mail Expandability

| BKSU        |          |        |           | VVMU Expansion Board |         |                      |           |
|-------------|----------|--------|-----------|----------------------|---------|----------------------|-----------|
|             | Default  | Option | Sub-Total |                      | Default | Option               | Sub-Total |
| VM Channels | 4        | 0      | 4         | VM Channels          | 0       | 1 port license x4    | 4         |
| VM Storage  | 16 hours | 0      | 16        | VM Storage           | 1 hour  | License for 15 hours | 16        |

| Total VM Channels/Storage |      |       |
|---------------------------|------|-------|
| KSU                       | VVMU | Total |
| 4                         | 4    | 8     |
| 16                        | 16   | 32    |

# Value Proposition

## Easily Expandable

- Base + Exp
- Trunks: Max 74
- Stations: Max 108 SLT/Digital
- IP/DECT capabilities to 140!

## Expanded VoIP & Mobility

- VoIP: Max 16 (8 on board)
- On/Off premise mobility

## Rich Features and Applications

- Enhanced VM/AA
- Unified Communications
- Robust application offerings

## Simple to Install & Manage

- Web Administration
- Install Wizard
- Broad endpoint support

# Ease of Administration

- HTML5-based web admin
  - (IE10), Firefox, Chrome
- Install wizard
- Favorite PGM (programming)
- Intuitive interface, quick access, logical layouts



# Ease of Administration

- TAB PGM
- Keeps most recent programmed areas in a TAB format for quick access
- Instant access via selecting the TAB

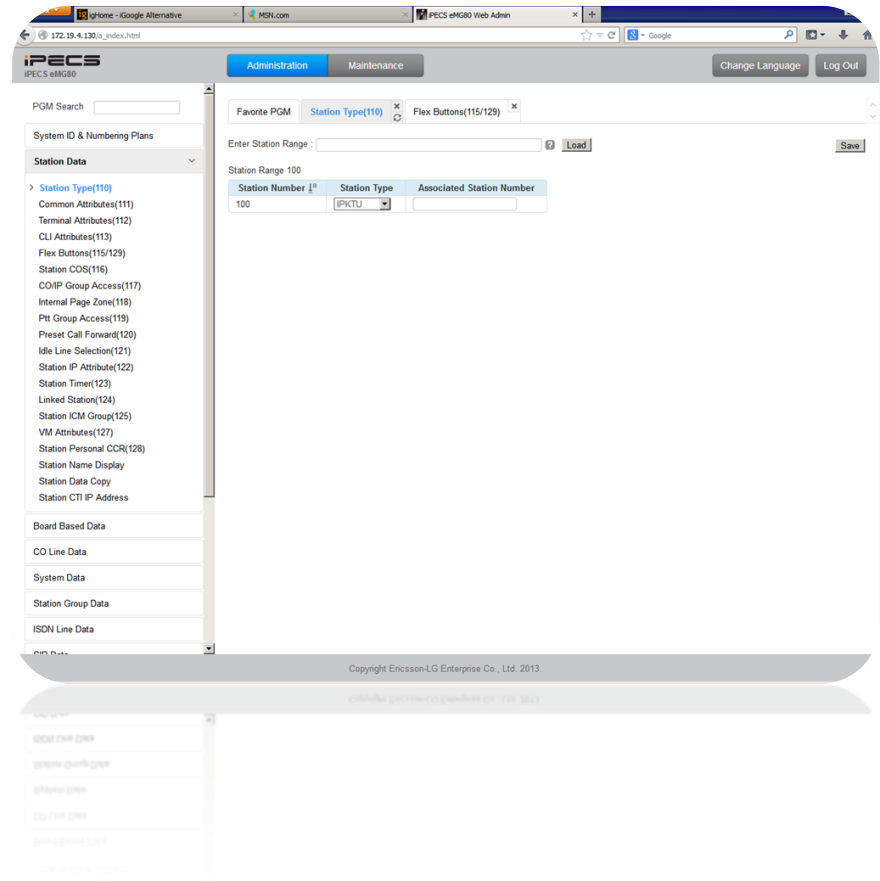



# Flexible Installation

## Wall Mount

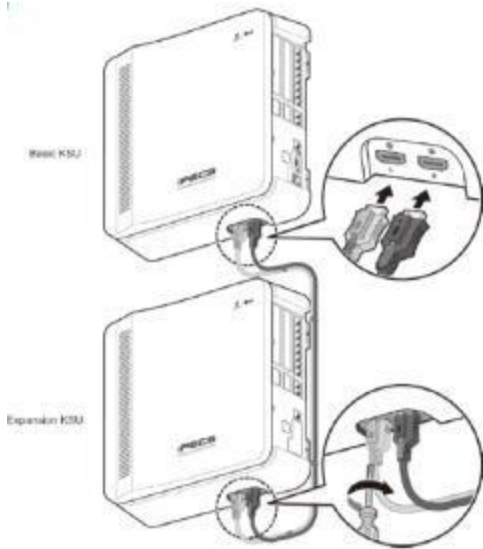

## 19" Rack Mounting

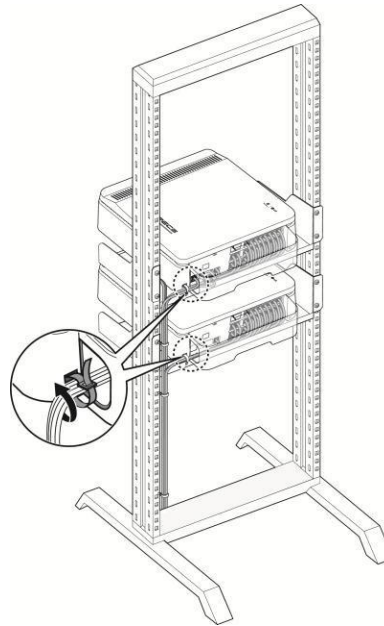

## Desktop

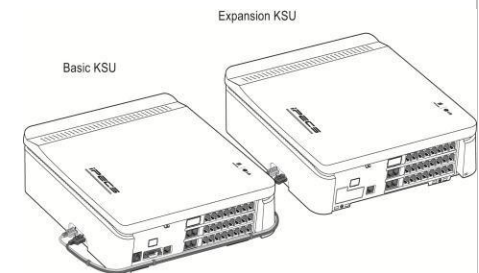

# Value Proposition

## Easily Expandable

- Base + Exp
- Trunks: Max 74
- Stations: Max 108 SLT/Digital
- IP/DECT capabilities to 140!

## Expanded VoIP & Mobility

- VoIP: Max 16 (8 on board)
- On/Off premise mobility

## Rich Features and Applications

- Enhanced VM/AA
- Unified Communications
- Robust application offerings

## Simple to install & Manage

- Web Administration
- Install Wizard
- Broad endpoint support

# Application Support

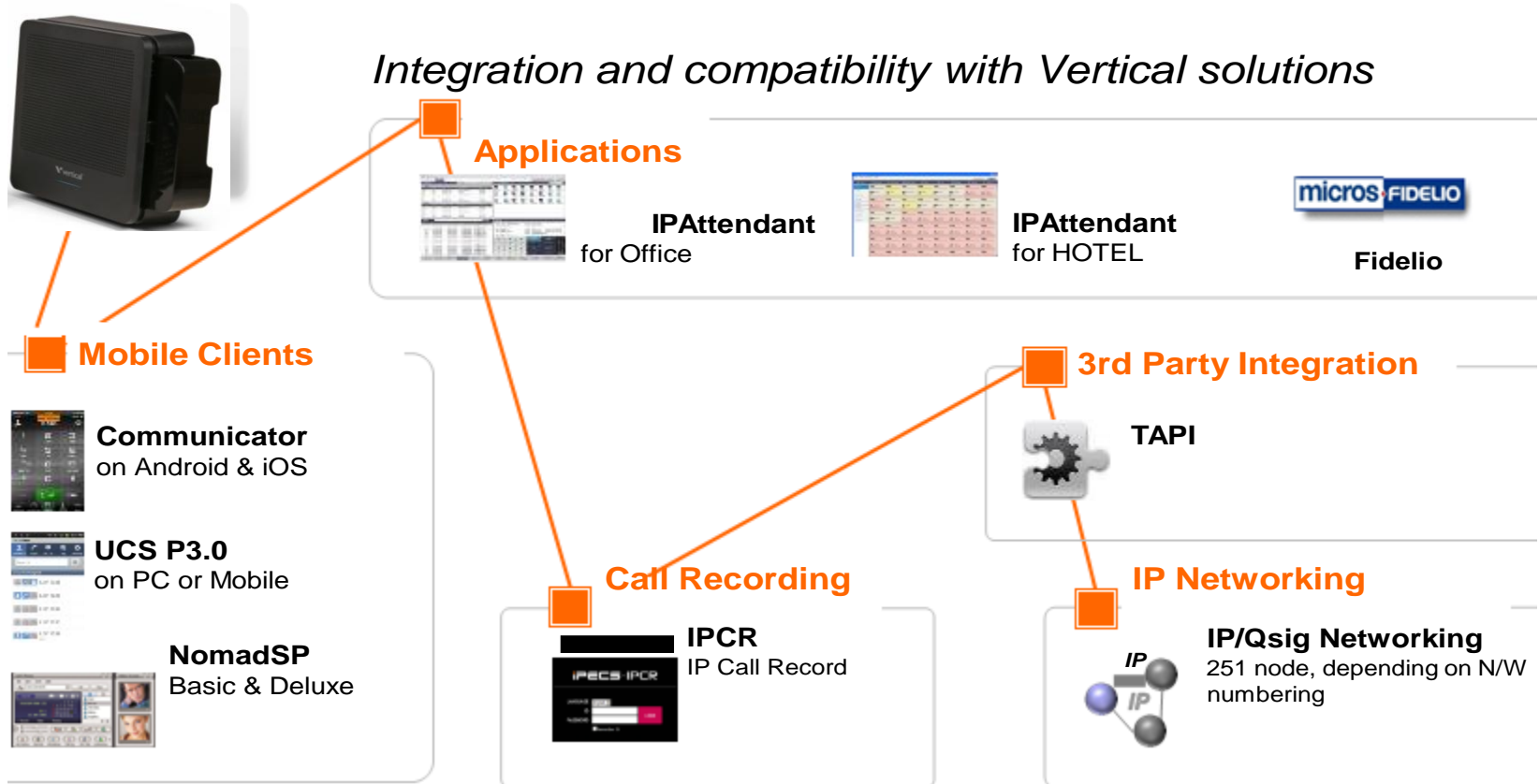

# Comprehensive Mobile Solutions

## Multiple choices of mobility for on-premise and off-premise environments

- DECT Cordless
- Vertical DECT Solution
- Vertical Communicator
- WiFi Cordless
- Mobile Extension
- SoftPhone

# Vertical Summit DECT Wireless

Cost effective, multi-cell solution

- In-building solution
- WTIB board supports 4 base stations
- Each base station supports 6 calls
- DECT technology, no WiFi security issues

| Category                  | Detail              |
|---------------------------|---------------------|
| Display                   | 1.5", 65K color LCD |
| Buttons                   | 2 soft, 5 way NAV   |
| Talk/Standby time (hours) | 15/150              |



# Vertical Summit Mobility

- SIP Client for smart phone
- Low cost by shifting existing calls placed on cellular network to Wi-Fi
- Android and iOS versions
- 2 free licenses with each system!

## PC Client

## Mobile Client

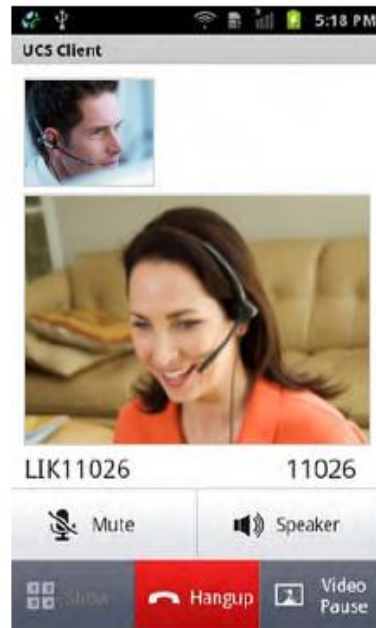

- Click Web to call
- Dialing from Outlook
- Outlook Contact Sync
- Outlook Schedule Sync
- Presence Sync with Schedule

# Communicator for Android

- Phone Book/Call Log/Paging
- SMS/Broadcast Message Sending & Receiving
- Hold/Resume/One-touch Pickup
- Call Forwarding
- One-touch Blind/Consult Transfer
- 3-way Conference Call
- DND
- High quality voice (GIPS voice engine / G.711, G.72)
- Recording

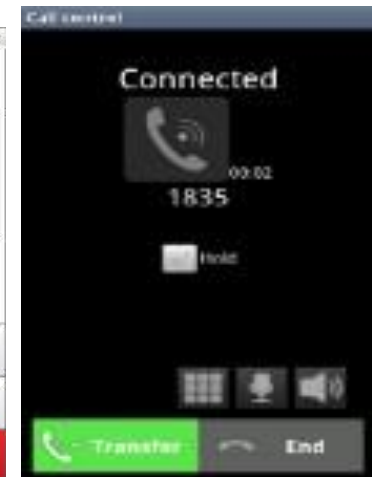
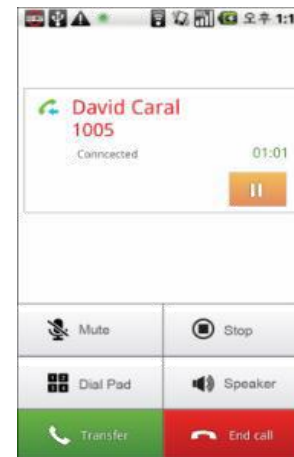

# Communicator for iOS

- Phone book/Call Log/Paging
- SMS/Broadcast Message Sending & Receiving
- Hold/Resume/One-touch Pickup
- Call Forwarding/Call Waiting
- One-touch Call Transfer
- 3-way Conference Call
- DND
- High-quality voice (G.711, G.729, G.722 support)
- Recording (.wav)

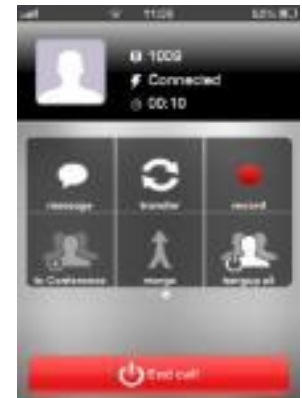
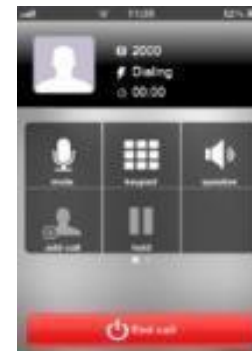



# Vertical Summit Soft Phone

- IP softphone
- 24 flexible buttons, BLF, Speed button
- Internal SMS
- On Demand Call Recording
- Incoming call pop-up
- Optimized for remote workers or call center agents
- 2 free with system!



# IP Attendant

- Displays attendant call handling and control functions
- Windows-based PC application
- Easy to use interface/flexible display layout
- Flexible call handling and operation
- IP softphone interface, no desk set required
- High quality voice communication using a PC

The screenshot displays the iPECS Attendant software interface. At the top, there is a menu bar with 'File', 'Tools', 'Setting', and 'Help'. The main interface is divided into several sections:

- Top Bar:** Shows 'Status' (SMS), 'Wake up', 'Paging', 'CFWD', 'SMS', 'E-mail', and 'Print' buttons. A status bar on the right shows the date and time '2010 - 02 - 21 13:55:55' and a 'LOG OUT' button.
- Call Control Panel:** A grid of buttons for call handling functions such as 'Call Park', 'Conference', 'Pick-up', 'ATD Transfer', 'Camp On', 'Call Back', 'Break-In', 'TRK Select', 'Hold', and 'Register'. A central display shows a phone icon, the number '1548', and the name 'Ji Hye Choi'.
- Wait / Hold Section:** Contains 'Phone Book', 'Call log', and 'Speed Dial' tabs. Below are tables for 'Wait' and 'Hold' lists, each with columns for Line, Name, Department, and Waiting time.
- Monitoring Group:** A grid of icons representing different call lines and their status, with a dropdown for 'All Group'.
- Condition Table:** A table with columns for Line, Name, Mobile Phone, and E-mail, containing contact information for several users.
- Dial Pad:** A numeric keypad with buttons for 'Call', 'Mobile', 'Message', 'E-Mail', and 'Paging'. It also includes function buttons like 'TRANS', 'REDIAL', 'FWD', 'CONF', 'DND', 'MSG/CB', 'ICM', 'PGM', 'SPEED', and 'MUTE'.

# IP Attendant for Hospitality (Phase 2)

- IP Attendant Hotel/Motel

| All Rooms | 2005                           | 2006                          | 2014                          | 2015                           | 2016                            | 2017                           | 2018                           | 2019                           |
|-----------|--------------------------------|-------------------------------|-------------------------------|--------------------------------|---------------------------------|--------------------------------|--------------------------------|--------------------------------|
| 1 st      | Room Class 20<br>Room Occupied | Room Class 1<br>Room Occupied | Room Class 1<br>To Be Cleaned | Room Class 3<br>Under Cleaning | Room Class 20<br>Out Of Service | Room Class 1<br>Room Occupied  | Room Class 1<br>Room Occupied  | Room Class 1<br>Room Occupied  |
| 2 st      |                                |                               |                               |                                |                                 |                                |                                |                                |
|           | 2020                           | 2021                          | 2022                          | 2023                           | 2024                            | 2025                           | 2026                           | 2027                           |
|           | Room Class 1<br>To Be Cleaned  | Room Class 1<br>Room Occupied | Room Class 1<br>To Be Cleaned | Room Class 1<br>Out Of Service | Room Class 1<br>Out Of Service  | Room Class 1<br>Out Of Service | Room Class 1<br>Out Of Service | Room Class 1<br>Out Of Service |

- Provides easy access to:

- Wake up calls
- Check in/out
- Room Status
- Group registration functions
- Billing service



# Hotel/Motel Feature Set (Phase 2)

Provides hospitality properties advanced features/functions

- MULTIPLE FRONT DESKS
- HOTEL SERVICE STATIONS
- REGISTER HOTEL NAME
- CHECK-IN / CHECK OUT
- CHANGE ROOM STATUS
- ROOM CHARGE DISPLAY & DELETING SERVICE STATIONS
- SMDR RECORD
- PRINT ROOM STATUS THROUGH RS232-C
- INTERCOM CALL DISABLE / ENABLE
- DEFAULT ROOM-TO-ROOM CALL GROUP
- ONE-TIME CO CALL ENABLE
- CHANGE LCD DISPLAY LANGUAGE
- REGISTER BAR AND MINI-BAR CHARGE
- MAID STATUS
- BATH ALARM
- ROOM RATE ASSIGN
- BABY LISTENING
- ADDITIONAL TAX FIELDS
- HOTEL SPECIFIC ITEMS
- SUITE ROOM WITH PERSONAL GROUP
- MOVE ROOM

# Vertical Summit for Contact Centers

- Flexible for Supervisors
  - Agent Call Monitor
  - Agent Status Controls
  - Agent “Help” Response
  - Group Status Viewing
  - Group Parameter Controls
- Flexible for agents
  - Request “Help”
  - Group Status Viewing

# Vertical Summit ACD Statistics Reporting

- Time stamp
- Total calls
- Number of unanswered calls
- Average queue time
- Longest queue time
- Total number of calls placed in queue
- Number of times calls experience all agents busy
- Total time all agents were busy
- Average ring time before answer
- Group Number
- Agent Number
- Number of ACD calls served
- Number of unanswered ACD Calls
- Average ring time before answer
- Average ACD call service time after answer

# Vertical Contact Center Services (Phase 2)

- Increase investment value simply w/ licenses
  - Dashboard shows real-time monitoring and status
  - Deploy remotely for networked systems
  - Manage based on time of day, skill sets, agent experience, IVR, web chat, call back services
  - Campaign and agent monitoring
  - Staff reporting
  - Add social media – Web Call Back feature
  - Call Recording
    - Basic today
    - Call Logging and server stored in Phase 2

# Unified Communications Solution (Phase 2)

People – Media – Personal Devices --  
Business Devices

- Capture telephone numbers from web pages for easy calling
- Use contacts to place calls simply and effectively
- Instant Messaging
- Conference Management
- Directory Management
- Easy to activate and access

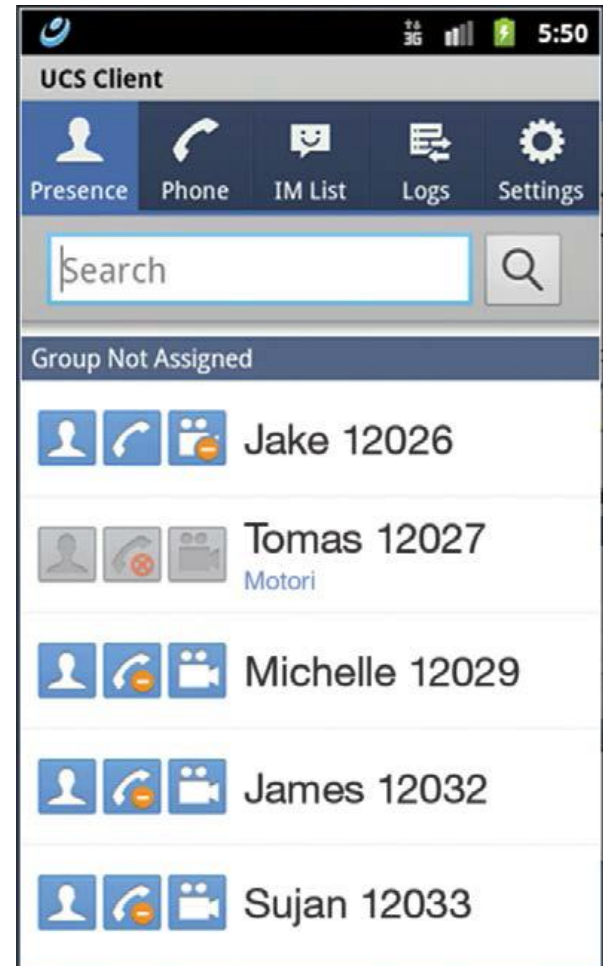



# UCS (Phase 2)

- Instant Messaging
  - 200 groups, 30 rooms, AES encryption
- Presence Status
  - 10 client, 4 desk phone, 4 web cam per user
- Individual call routing
  - 10 per user, presence based routing
- Directory Management
  - ACT, Outlook, Exchange
- 6-party video conference
- Application Sharing (6 party)
  - Desktop share, whiteboard, real time app



# Summit Network Management (Phase 2)

- Manage registered systems in real-time
- Manage, monitor and maintain resources and system components
- Web-based access
- Traffic statistics

The screenshot displays the iPECS NMS interface. On the left is a 'System Explorer' tree showing a hierarchy of groups: Main Office (20 COs), East Branch Group (6 branch offices), and West Branch Group (6 branch offices). Below it is an 'Alarm/Fault Summary' panel showing 10 critical faults, 2 major faults, and 3 minor faults. The main area shows a table of 'CO Device Information' for the '150,150,150,2 (Main Office : 5,0Bc)' group. The table lists 20 devices with columns for Dev No., Device Type, IP Address, Firmware Version, Location Mode, and Device State. On the right, there are several panels: 'Channel Information' showing CO Channel Index 1, CO Name, CO Type DID, and CO Group Number 2; 'Device Information' showing details for device 33 (ISDN-PRI GW, Firmware 4.0Cd); and 'Device Network Information'.

| Dev No. | Device Type    | IP Address     | Firmware Version | Location Mode | Device State   |
|---------|----------------|----------------|------------------|---------------|----------------|
| 33      | ISDN-PRI GW    | 192.168.150.41 | 4.0Cd            | Local         | Active         |
| 34      | VOIPM24 GW     | 150.150.150.3  | 4.2Ba            | Local         | Active         |
| 35      | PSTN-LOOP GW   | 218.51.218.51  | 1.0Ea            | Local         | Disconnected   |
| 44      | VOIP GW        | 150.150.150.2  | 4.0Av            | Local         | Out-of_Service |
| 46      | PSTN-LOOP GW   | 150.150.140.55 | A.0Gg            | Local         | Out-of_Service |
| 56      | PSTN-LOOP GW   | 67.186.126.170 | A.0Gk            | Remote RSGM   | Active         |
| 74      | LGCM LOOP 8 GW | 10.64.64.23    |                  | Local         | Disconnected   |
| 77      | LGCM LOOP 8 GW | 0.0.0.0        | 1.0Af            | Local         | Out-of_Service |
| 114     | PSTN-LOOP GW   | 218.236.133.76 | A.0Gi            | Local         | Disconnected   |
| 126     | LGCM LOOP 8 GW | 150.150.140.91 | 4.0Ed            | LocalRemote   | Active         |
| 141     | LGCM LOOP 8 GW | 0.0.0.0        |                  | Local         | Disconnected   |
| 142     | PSTN-LOOP GW   | 150.150.140.54 | A.2Gr            | Local         | Disconnected   |
| 143     | PSTN-LOOP GW   | 150.150.140.35 | B.2Gq            | Local         | Disconnected   |
| 157     | PSTN-LOOP GW   | 58.75.148.209  | 1.0Da            | Local         | Disconnected   |
| 183     | LGCM LOOP 4 GW | 61.41.110.248  | 4.0Bf            | Remote        | Active         |
| 199     | PSTN-LOOP GW   | 211.172.59.32  | A.0Gj            | Local         | Disconnected   |
| 202     | PSTN-LOOP GW   | 192.168.2.21   | A.0Gj            | Remote RSGM   | Active         |
| 217     | VOIP3 GW       | 150.150.150.95 | 4.0Bf            | Local         | Disconnected   |
| 218     | LGCM LOOP 8 GW | 61.41.110.17   | 4.0Cb            | Remote        | Active         |
| 219     | LGCM LOOP 8 GW | 61.41.110.14   | 4.0Bf            | Remote        | Active         |

# Vertical Summit Support

- Marketing
  - Full Color Brochures
  - Product Guide
  - 9000 Series Phone Brochures
  - Product Comparison vs. SBX/MBX/Wave
  - Competitive Information
  - Video's
  - Postcards
  - Trade show tools
- Summit Answers!

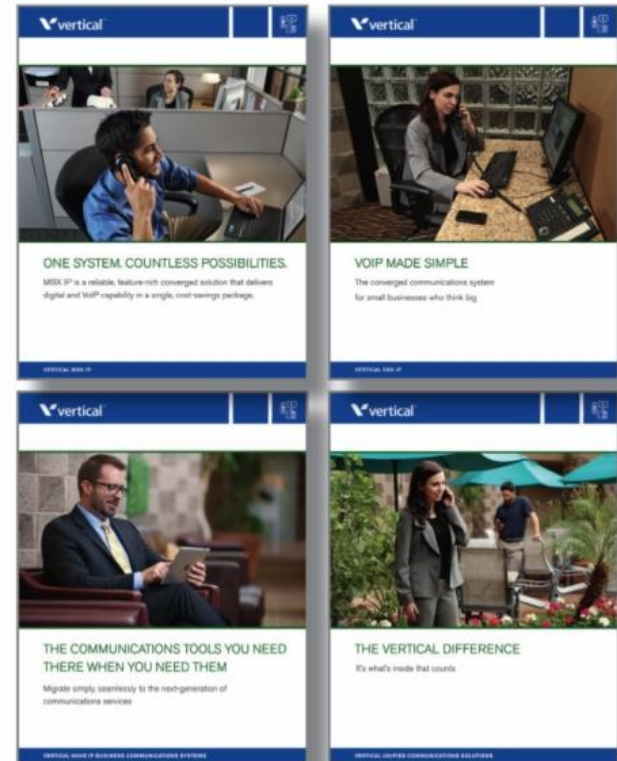

# 2014 Training

- Certification training coming to you!
  - 1-day technical certification
  - Road Show cities
  - Distributor locations





**800.873.5528**  
**WWW.TARGETD.COM**

---

# ARE YOU READY FOR VERTICAL SUMMIT??!!

For questions regarding the Vertical Summit or to sign up to become a certified Partner, contact: Dana Wiggin

[dwiggin@vertical.com](mailto:dwiggin@vertical.com)

480-374-8844

don't settle  
for less! >

A thick, solid blue horizontal bar at the bottom of the slide, with three rectangular cutouts on the right side.