



# Back Office Recorder 4iP Installation Guide



## Intelligent Recording Limited

Downloads Available at [www.usbcallrecord.com](http://www.usbcallrecord.com)

UK Office +44 (0) 1909 512148

US Office +1 949.587.1226

Copyright ©Intelligent Recording Limited July 2012.

## Welcome!

This guide describes the installation procedures for the Intelligent Recording BackOffice 4iP software as a centralized Call Recording and storage solution.

The BackOffice 4iP software can be used as a 100% IP recording solution or can be combined with a combination of Intelligent Recording's hardware options as described below to provide a complete solution in an office with a combination of Digital and IP phones.

## Hardware

The following section outlines the hardware options that can be used in combination with IP telephones with the BackOffice 4iP Software.

BackOffice 4iP Software can be used with the any of the following hardware-types. This hardware can also be mixed and matched on the same host PC in order to meet exact recording requirements:

- Dig16
- Dig04
- Ana 02,04,08
- ipTap
- Universal Adapter 3.0

Locate the Hardware Description you are installing on the next few pages and follow those instructions. The software installation is described in detail later in this document and is the same for all of the hardware devices.

## XTR Dig16 USB Device



The Xtension Recorder Dig16 hardware connects via a T-Connect Tap of each digital pair directly from the PBX. The Dig16 requires external power. Up to 3 Dig16 devices can be connected to a single PC (providing 48 ports). If more devices are required additional PCs can be utilized.

### Digital 16 Connections

The Dig16 consists of 4 groups of 4 RJ11 connectors with associated LED lights (NOTE: these LEDs DO NOT indicate recording status but are used to show device status)

- One PC USB connector, from which the device streams all speech and control channel information up to the host PC and the Xtension Recorder BackOffice application.
- Sixteen RJ 11 Digital Phone line connectors that passively ‘tap’ across the PBX/Keyset digital connection and ‘listen’ in high impedance mode to the signaling on the line. Xtension Recorder does not affect in any way the telephone operation with or without connection of the host PC.
- External Power Connection and Power Supply.
- **NOTE: Only use supplied length USB cable(1 Meter). Using longer length USB cables WILL cause devices to fail.**

## Xtension Recorder Dig04 USB Device

The Dig04 Recorder hardware connects via a T-Connect Tap of each digital pair directly from the PBX. It derives power from the USB connection with the host PC.



Up to 3 Dig04 devices can be connected to a single PC (providing 12 ports). If more ports are required, you can utilize the Dig16 devices as well as use the Dig04 to extend the number of ports on a system using a Dig16 (i.e. 20 ports = (1)Dig16 + (1) Dig04).

### Connections

The Dig04 USB recording device has 5 connectors and 4 LED indicators (NOTE: these LEDs DO NOT indicate recording status but are used to show device status)

- One PC USB connector, from which the device derives its power and streams all speech and control channel information up to the host PC and the Xtension Recorder BackOffice application.
- Four Digital Phone line connectors that passively ‘tap’ across the PBX/Keyset digital connection and ‘listen’ in high impedance mode to the signaling on the line. Xtension Recorder does not affect in any way the telephone operation with or without connection of the host PC.
- **NOTE: Only use supplied length USB cable(1 Meter). Using longer length USB cables WILL cause devices to fail.**

## Digital 04/16 Station Wiring Example

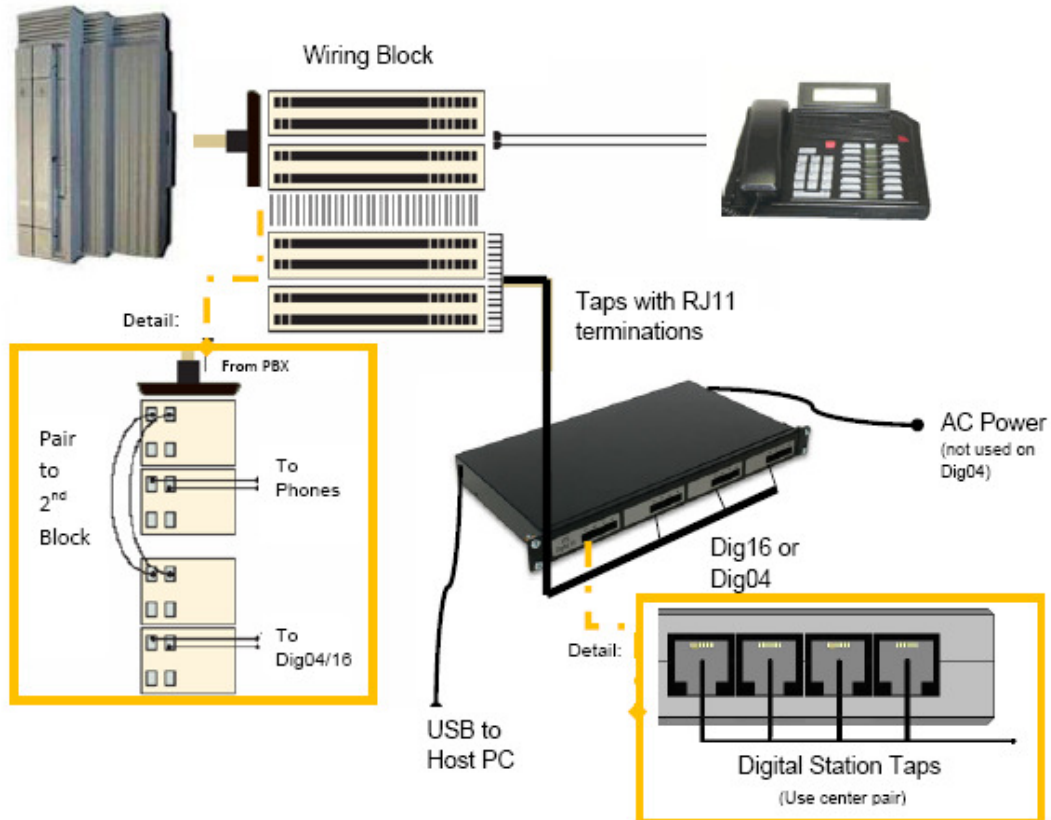

The Dig04/16 records directly off the Digital Station Pair of compatible PBX/Key systems using a parallel tap of the same pair that powers the Digital Phone. The above Diagram illustrates one way to accomplish the parallel tap required, although there are many ways to get to the same end.

**Please note, regardless of which pair powers the Digital Station (i.e. as with Inter-Tel and Panasonic) the connection or tap into the Dig04/16 needs to be on the inside pair of the RJ11 connector.**

# XTR Analog Recording Solutions



## Analog 02, 04 & Analog 08



The Analog 02, 04 and Analog 08 Recorder hardware connect via a T-Connect Tap of an Analog Telephone Line or Analog Station. It derives power from the USB connection with the host PC.

Up to 3 Analog Recording Devices can be connected to a single PC (providing 24 ports). If more ports are required, you can add additional host PCs.

### Front Panel

**Power LED:** Indicates operational and communication status.

- Steady ON: Power is OK, USB Communication is Good.
- Slow Flashing: Power is OK, NO USB Communication
- OFF : No Power or Faulty Device.

### Rear Panel

There are USB and Line Connectors on the Rear Panel.

**USB Connector :** This connection is used to connect the Recorder to the Host PC.

**Line Inputs:** Each line wires directly to the inside pair of the jack on each device.

***The Analog 02/04/08 Recorder should connect to the computer using the provided cable. The Recorder should be connected directly to the computer (without a hub). If more USB ports are needed, use internal PCI –USB controller cards to expand the number of USB ports on the PC.***

## Installation

The BackOffice 4iP Recorder is capable of recording both IP traffic as well as Digital Station ports using our Digital Recording products (Dig04 and Dig16).

To record IP Phones, the BackOffice 4iP Recorder is connected to mirroring Switched Port Analyzer (SPAN) ports of the network switches that reflect the traffic to be recorded. VoIP recording is available with every telephony environment that uses standard Real Time Protocol (RTP) for the voice packets.

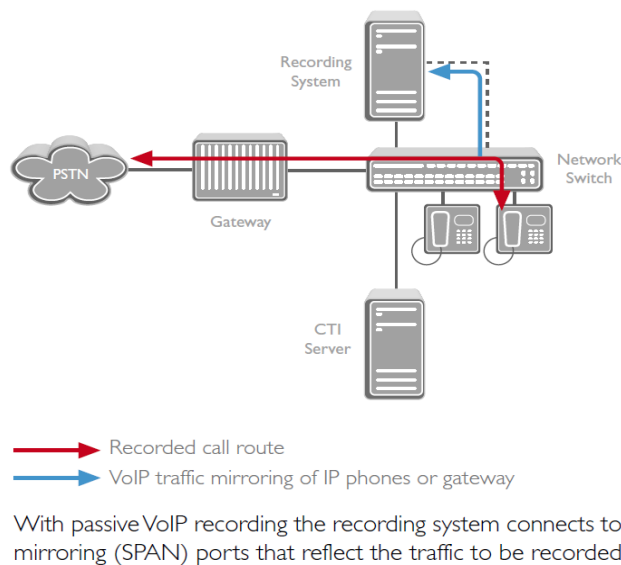

Recording in a VoIP system utilizes a commonly found feature of IP network switches called port mirroring. This feature provides the capability to copy data packets from one port on the switch to another destination on the network.

Although this feature was originally intended to provide monitoring and diagnostic support in a network, it is very useful as a way to record VoIP conversations. Using this method, the switches in a network are configured to mirror data packets from VoIP phone ports to ports on a VoIP call recording system.

## HOST PC Requirements

The specs below are minimum specifications for use with any of the XTR Hardware solutions or IP recording when utilizing the BackOffice 4iP Software. If used in a hybrid environment with Digital Recording Hardware, follow guidelines below for minimum spec when using IP and Digital recording on same PC:

### **XtR Digital 04, Analog 02/04/08 & IP Recorder**

Operating System: Windows XP Professional Service Pack 2 or Better (Win 7 Recommended)

Processor: Intel E5400, Dual Core, 2.7 GHz or equivalent

Maximum Hardware Devices: Up to 3 Digital or Analog devices supported per PC

USB: 1.1 or 2.0 – One dedicated USB Port per Device

RAM: 1 Gb

Hard Drive: 168 hours of recording per Gb of disk space available

NIC : 2 NIC cards required (unless using ipTap as interface for IP Recording or no IP Recording Required )

### **XtR Digital 16(s) & IP Recorder**

Operating System: Windows XP Professional Service Pack 2 or Better (Win 7 Recommended)

Processor: Intel E6500, Dual Core, 2.93 GHz or equivalent

Maximum Hardware Devices: Up to 3 Dig 16 devices supported per PC

USB: 1.1 or 2.0 – One dedicated USB Port per Device

USB Controller: 1 Dedicated USB Controller per Device

RAM: 2 Gb

Hard Drive: 168 hours of recording per Gb of disk space available

NIC : 2 NIC cards required(unless using ipTap as interface for IP Recording or no IP Recording Required )

*All BackOffice Installations: **The host PC should be a NEW and dedicated PC.** It is not recommended to load the BackOffice Software and install the XTR Hardware on a PC that is shared with other critical applications; doing so may cause conflicts that could jeopardize the stability of the PC or the applications.*



## **STEP 1: Prepare the Location**

If also recording Digital or Analog ports, it is important that the wiring for the extensions is within 6 feet of the PC location. For this reason, it is recommended that the PC for the BackOffice location be located near the PBX MDF for extension wiring.

The installer will need to prepare the wiring to tap off the digital pair as shown in previous diagram for the Digital Recorders or off the Analog line or Signal if using the Analog Recorders.

## **STEP 2: Set Up the PC**

1. Set up the PC with the appropriate number of USB controller cards for the number of XTR devices (if applicable) . Follow the installation instructions for the USB controller card carefully.
2. Connect PC to the LAN for supervisor access to the stored calls as well as to facilitate Windows and Software updates or remote support as needed.
3. Connect any USB hubs if applicable.
4. Make sure there are no 'Power Setting' options selected that will cause the PC to hibernate or hard drives to turn off.

We recommend that Windows auto updates be turned OFF or set to notify.

## **STEP 3: Install the XTR BackOffice4iP Software**

**If you will be recording IP Phones it is important to first install the latest version of WinPcap from <http://www.winpcap.org>. This is required so the recorder can capture the IP packets being presented to the recording system.**

Next, to install Backoffice 4iP program place the program CD in CD-ROM Drive - the installation will run automatically. If the interface does not auto-run browse the CD directory and double click Autorun.exe.

**Select the VOIP, Digital or Analog options you are installing when prompted.**

## **STEP 4: Install Xtension Recorder Devices**

(skip if 100% IP Phone Installation)

### **Load Device Drivers**

1. Make CERTAIN you are logged into PC with Administrative Rights, then Connect USB cable from XTR Recorder device to PC (one at a time)
2. Windows should respond with 'Found New Hardware Wizard' . Direct the wizard to the appropriate driver folder. The drivers will be installed under: C:\Program Files\Intelligent Recording\Recorder\Drivers

- a. If prompted, select "Continue Anyway

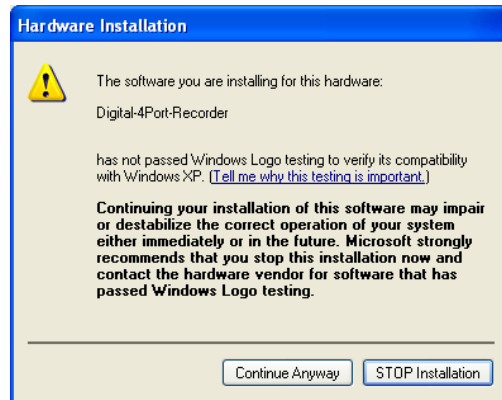

If installing the Dig16, *Windows will load a driver for each 4 port bank of ports separately, so this process will be repeated 4 times for each Dig16 installed.*

## If 'Found New Hardware Wizard' does not Launch

Open [Device Manager](#) (Control Panel >System>Hardware>Device Manager)

Locate 'Unknown Device' – Right-Click on it- the unknown device will either be under the Universal Serial Bus controllers or under 'Other device' as shown below:

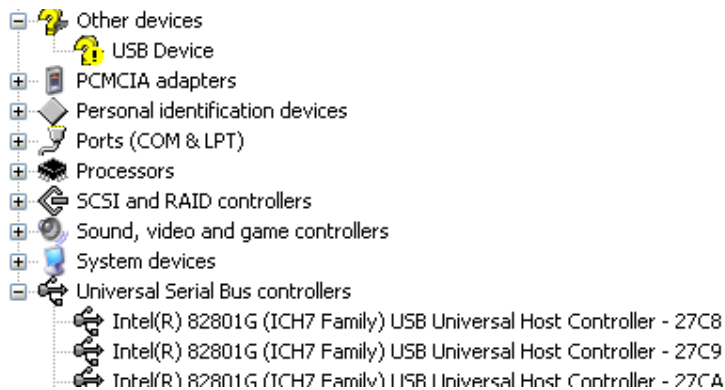

### Select Update Driver

This will launch 'New Hardware Wizard' – follows Steps 3-6 above

## Check Devices in Device Manager

Once all devices are connected view the devices in Device Manager to ensure proper installation. The Digital Recorders will show as 'Digital Recorder', the Analog 04/08 as 'Multi-Port Analog Recorder', the Universal Adapter 3.0 will show simply as a Composite USB device.

## Connect Station Wiring

Finally, connect each telephone wiring as directed in the previous Hardware Section. Be sure to keep track with extension is connected to each port of the devices. It is recommended that you label each 'tap' at the RJ 11 end with the corresponding extension number.

## Software Configuration

Once the WinPcap and the Backoffice4iP program has been installed the application needs to be configured to record the IP packets being presented to the recording system. The number of licensed ports is controlled by the USB dongle received with the system, or licensed directly the ipTap is using this as your interface to the system.

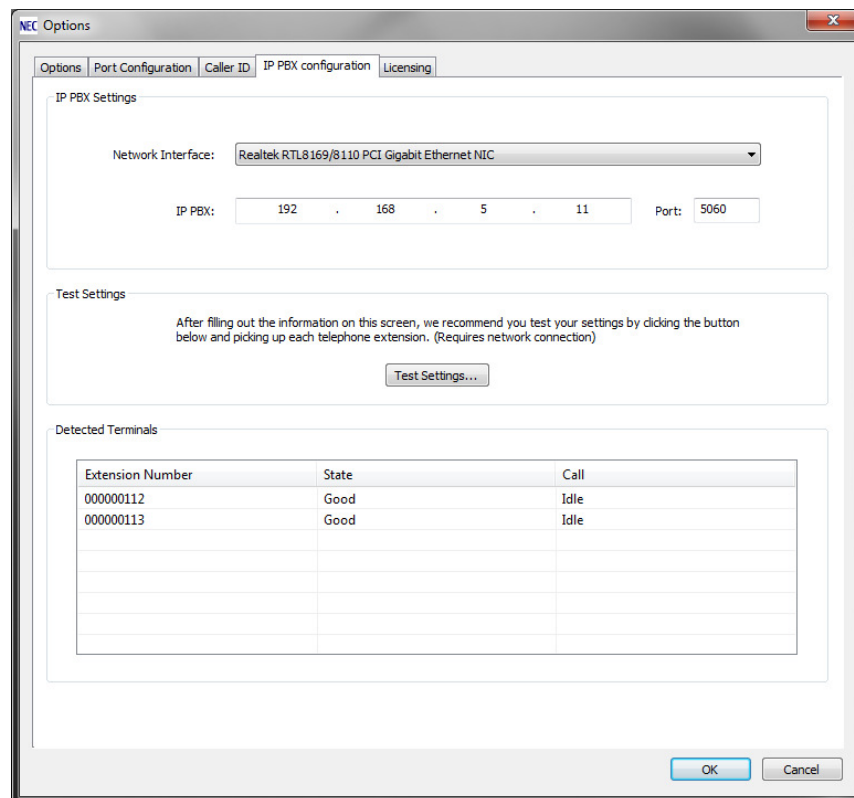

**Network Interface:** Specify the network adaptor which will receive the port mirroring IP packets.

**IP PBX:** Specify the IP address of the IP PBX.

**Port:** Specify the IP Port the VoIP traffic is presented on in most cases this should be left at the default of '5060' which is default port for SIP as this is the only VoIP protocol the recording system supports.

**Test Settings:** When the above settings have been configured selecting this button will look for registered phones on the network. In order for a phone to be considered as registered the phone needs to go Off-Hook.

Once the phones have been registered with the recorder the phone extension can be configured for recording. The number of VoIP phone extension that can be recorded is based on licensing, only the allowed number of extension are permitted to record calls, the other will be disabled.

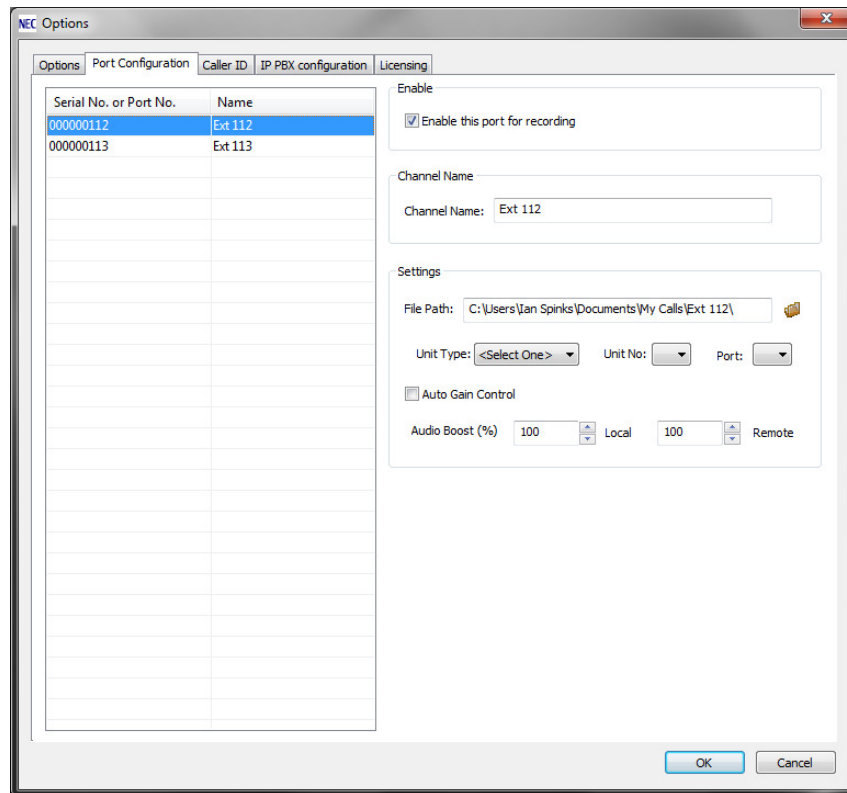

**Enable:** The current recording enable state of this port, for VoIP channels this settings can only be set if the licensing permits.

**Channel Name:** Name of the Channel as the recordings are to be identified for this port.

**File name:** Specifies the location where the recorded calls are to stored.

**Unit Type:** Select what type of recording device is installed for this

**Unit No:** Select Unit number. When more than one recording device is installed then label with a unit number (i.e. 1, 2 etc)

**Port:** Identify which port or channel (from left to right 1-4) on device.

**Auto Gain Control:** This setting will balance the audio level of the resulting recording based on audio levels received.

**Audio Boost:** If desired, this enables the over-ride to the Auto-Gain settings and provides manual boost to either side of the recording. Note, 100% and 100% is default and is the recording with NO gain. If you choose to boost the recording levels, you would increase from 100%.

## Configuring Digital Station Ports

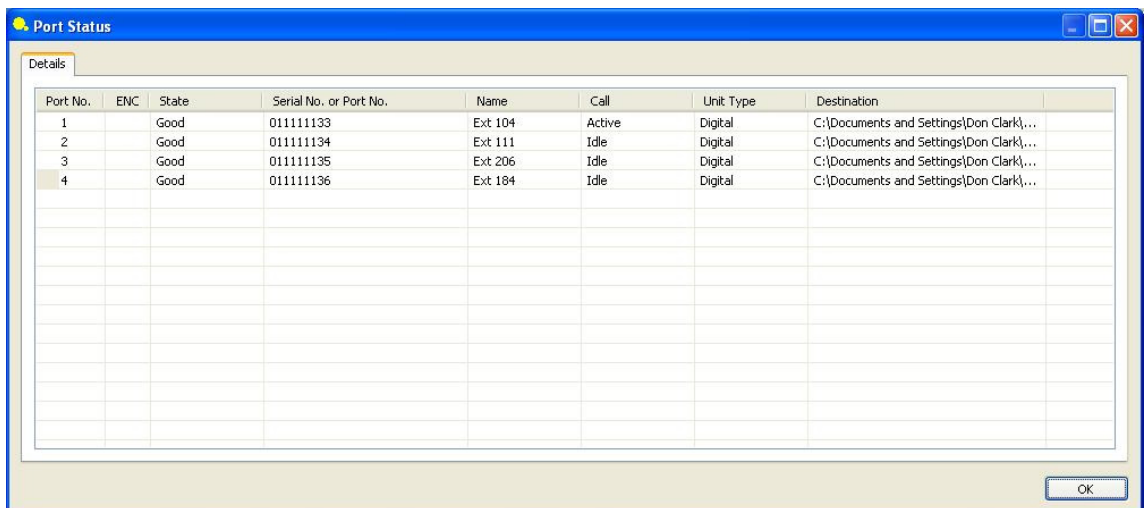

The screenshot shows a window titled "Port Status" with a "Details" tab. It contains a table with the following data:

Port No.	ENC	State	Serial No. or Port No.	Name	Call	Unit Type	Destination
1		Good	011111133	Ext 104	Active	Digital	C:\Documents and Settings\Don Clark\...
2		Good	011111134	Ext 111	Idle	Digital	C:\Documents and Settings\Don Clark\...
3		Good	011111135	Ext 206	Idle	Digital	C:\Documents and Settings\Don Clark\...
4		Good	011111136	Ext 184	Idle	Digital	C:\Documents and Settings\Don Clark\...

The status screen can be viewed by Right-Click on System Tray icon and Select 'View Status'. Once the Digital Recording devices are connected to the PC and the drivers are loaded, they will appear in the status screen as unconfigured. The Recorder Port Status screen is not used for configuring, it is only a display of current status of the Recorder Hardware and Software :

**Port No:** Numerical identifier of Port

**Enc:** Identifies if the port is enable for Encryption

**State:** The current state of the port.

**Serial No. or Port No.:** Serial number of the port or user defined port details.

**Name:** The name of the channel.

**Call:** The current call state of the port.

**Unit Type:** Type of the hardware device.

**Destination:** The destination where the call is going to be stored.

# 1) Options Set Up

Exit Status Screen, then right Click on Sys Tray Icon and select 'View Options'

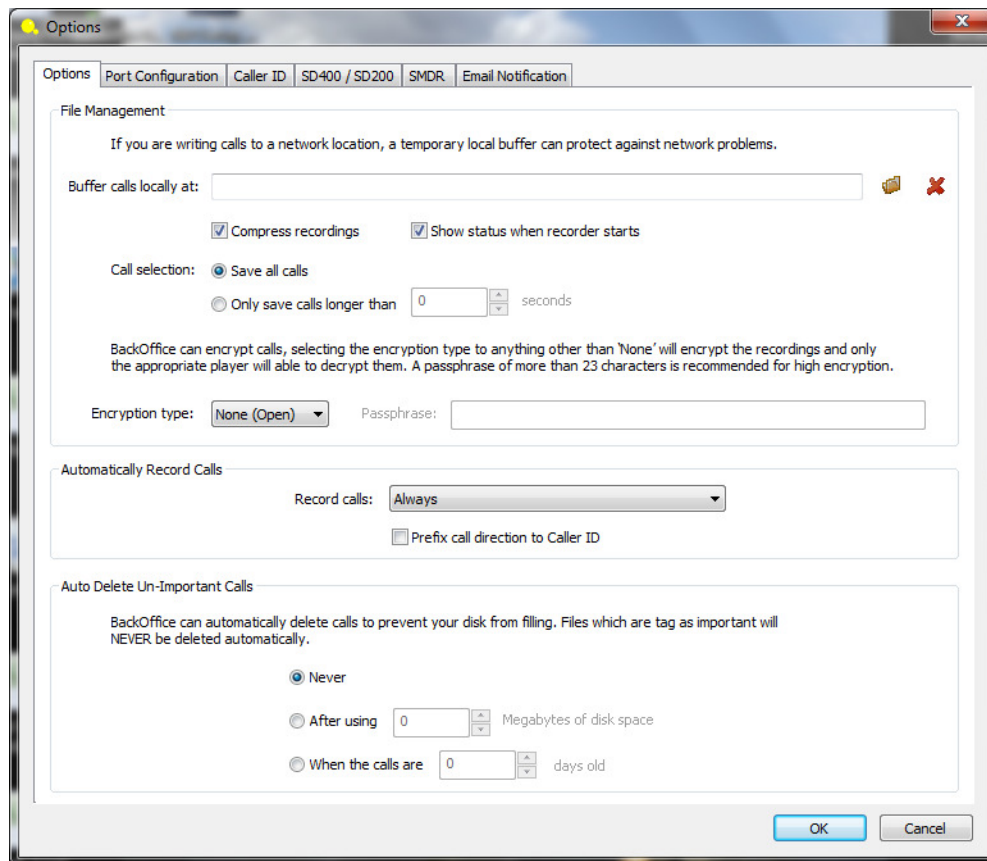

**Buffer calls:** Sets a location to buffer the 'live calls' during recording, once the call is completed the file is moved to the storage location specified for each port. The Calls Buffer should only be used if you will be storing the call files to a location other than the local recording PC (ie, network storage location).

**Compress recordings :** Uses a compression technique to store the recording more efficiently (168 Hours per GByte)

**Call Selection :** Only calls greater than the preset time period will be saved.

**Encryption type:** NOTE: requires purchase of Encryption Licensing – Contact your reseller for details.

**Automatically Record Calls:** This setting should be set to “Always”

**Auto Delete Un-Important Call,** Can be set to delete calls after ‘x’ number of days or after a define amount of disk space has been used.

NOTE: Calls marked as Important during playback will NOT be deleted by this setting.

The Recorder will now record every call to and from the telephones. It is important to use proper procedure to shut down the application and PC when necessary.





**Enable:** Check the box to enable the port

**Channel Name:** Name the Channel as you want the recordings to be identified for this user. After naming, clicking the  icon next to the line will create a storage folder for this user under the My Documents/My Calls/'channel name' folder. This can also be changed to another location if preferred.

**Settings Options:**

This area of the program allows the installer to change the reference of a recorder channel from serial numbers to an easily recognizable name (ie Digital 04-Unit 01- Port 01) as well as manually map to the preferred storage location for each port and set audio balancing if changes are required.

**File Path:** This is auto-configured is desired, but can be changed by browsing to a folder location desired. It is highly recommended that each channel or port have their own folder for storage. This will make it much easier and quicker to find specific calls.

*Unit Type/Unit No. and Port No. are used for reference only –they do not need to be configured for the software to record.*

**Unit Type:** Select what type of recorder hardware installed for this channel (in example above it is a Dig04)

**Unit No:** Select Unit number – it is recommended that when more than one is installed that the installer label then with a unit number ( ie. 1, 2 etc)

**Port:** Identify which port or channel (from left to right 1-4) on device.

**Auto Gain Control:** This setting is recommended, the recorder system will balance the audio level of the resulting recording based on levels received.

**Audio Boost:** If desired, this enables the installer to over-ride the Auto-Gain settings and provide manual boost to either side of the recording. Note, 100% and 100% is default and is the recording with NO gain. If you choose to boost the recording levels, you would increase from 100%.

Once all ports are configured , click 'OK' to exit this screen. In most cases, this completes the installation of the software.

### 3) Port Configuration (for Ana02/04/08 only)

Analogue

Confidence Beep    Beep Period:  Seconds

Caller ID Mode:     First Ring     Polarity Reversal

Call active detected by:     Audio Level     Line Voltage Detect

Trigger Level:     Voltage Level:

Silence Timeout:

**Confidence Beep** - this will play a tone audible to parties on the conversation

**Caller ID Mode** - In most cases Caller ID (if provided) will be captured using the 'First Ring' method.

**Call Active by** - If connected to outside lines, use Line Voltage detect, if off PBX extensions you will need to use Audio Level.

**Trigger Level** - use only if Audio Level is used, in most cases 30 will suffice, but if calls do not start , lower this level.

**Voltage Level**- recommended to leave at default , but can increase or decrease sensitivity to Voltage Shift.

**Silence Time Out**- determines how long a pause will be used to determine 'stop' of a conversation when audio level is used. Recommend 8 seconds.

## 4) Caller ID Tab:

Options

Options | Port Configuration | Caller ID | SD-400 / SD200 | SMDR | Email Notification

Caller ID

Dialled digits override the LCD display for caller ID

Use caller ID from

Delay before grabbing caller ID  seconds.

Helps where all calls are forwarded via operator or auto-attendant

Update caller ID  Continuously  
 Never  
 Every  seconds

Trigger audio recording from remote end only

Use with open mic headphones

Audio amplitude to trigger recording  Local  Remote

A figure of around 35 is typically good, unless you have a noisy system

Silence period halt recording  ms

OK Cancel

These settings are used to customize the Caller ID/Digits Dialed features of the program that determine when and how the caller ID is taken from the display of the telephone (on supported systems). It is recommended that you contact Intelligent Recording Technical Support for assistance if changes in this area are required.

## 5) E-Mail Notification Tab:

Use this section to setup email notification if service fails or hardware is removed. Note: Email Address CANNOT user Secure SMTP.

The screenshot shows a software window titled "Options" with a tabbed interface. The "Email Notification" tab is selected. The window contains the following sections:

- Email Notification:** Includes a checked checkbox for "Enable email notification". Three other checkboxes are unchecked: "Send alert if the number of unallocated calls is greater than 5 calls", "Send alert if a hardware failure or unplug has been detected", and "Send alert if a recorder service has started or stopped".
- Statistics:** Displays the following values:
  - Number of calls recorded today: 0
  - Number of unallocated calls today: 0
  - Last unallocated call: None
  - Last recorded call: None
  - Total number of unallocated calls: 0
- Test Email Settings:** Contains a text box with the instruction: "After filling out the information on this screen, we recommend you test your settings by clicking the button below. (Requires network connection)". Below the text is a "Test Settings..." button.
- Email Server:** Includes several input fields:
  - Outgoing mail server (SMTP): [Empty text box]
  - Port: 25
  - Username: [Empty text box]
  - Password: [Empty text box]
  - To: [Empty text box]
  - Subject: [Empty text box]
  - Mail message: [Empty text area]

At the bottom right of the dialog are "OK" and "Cancel" buttons.

## Choosing and Installing Player Options

There several Player options available with the BackOffice Recording solution.

- **Desktop Player** can be loaded on an individual user's PC, giving the user complete access (although restrictions can be applied) to call management: deleting calls, e-mailing conversations, exporting to wav file, etc. This software can be downloaded from [www.usbcallrecord.com](http://www.usbcallrecord.com) for free.
- **Call Manager Player** enables a supervisor(s) to search for calls, playback calls, associate notes about the calls and mark them as important as well as delete or email conversations. Please refer to the Call Manager Installation Manual for instructions or the instructions provided on the CD.
- **XTR Reporter Pro**- same functionality as Call Manager as well as advanced visibility, access, analysis and reporting tools for Xtension Recorder Administrators that want to do more than simply listen to recorded calls, for those that want to use data to help manage their business. XTR Reporter Pro also adds the Agent Evaluation module Call Scoring. Provides customized scoring forms and criteria and detailed support to quickly identify strengths and weaknesses within your business.

These Packages can be applied in any number of configurations within the organization providing control and management where needed and simple playback in other locations.

### *Contact Intelligent Recording*

For more detailed information regarding the products discussed in this document or to inquire where to purchase, you can visit us on the web at [www.usbcallrecord.com](http://www.usbcallrecord.com) or call

UK Office +44 (0) 1909 512148

US Office +1 949.587.1226